

**INSTRUCTION MANUAL**  
**MODEL 701**  
**ELECTRONIC RELAY**

**KEITHLEY INSTRUMENTS, INC.**  
**CLEVELAND, OHIO**

#### WARRANTY

We warrant each of our products to be free from defects in material and workmanship. Our obligation under this warranty is to repair or replace any instrument or part thereof, except tubes, transistors, fuses, and batteries, which, within a year after shipment to the original buyer, proves defective on examination.

#### DAMAGE IN SHIPMENT

Be sure to include the instrument model number and serial number in all communications. If the instrument is damaged when received, or fails to operate properly, a claim should be filed with the carrier. Upon receipt of the claim agent's report, we will inform you regarding repair or replacement.

#### REPAIRS

When returning an instrument for repair or recalibration, it should be securely packed against shipping damage and sent to the factory, freight prepaid. A brief letter describing the difficulty should accompany the instrument.

CONTENTS

	SECTION
INTRODUCTION . . . . .	I
SPECIFICATIONS . . . . .	II
DESCRIPTION . . . . .	III
OPERATIONS . . . . .	IV
MAINTENANCE . . . . .	V
Schematic Diagram	
Voltage and Resistance Chart	
Replaceable Parts List	

## SECTION I - INTRODUCTION

The Model 701 Electronic Relay is a sensitive direct current voltage discriminator which actuates an Electro-magnetic relay when a predetermined voltage level is exceeded. Its action may be made either locking or non-locking and may be wired so that it is fail-safe for a signal which exceeds the trip point or for a signal which decreases below the trip point.

The Electronic Relay features a variable "Trip Level" from 0.2 to 10 millivolts with an input impedance of 1 megohm. The trip level is adjustable by means of a calibrated dial on the front panel. The instrument is normally furnished as a voltage actuated device but can be used to control currents down to  $10^{-8}$  amperes by shunting an appropriate resistor across the input.

The Model 701 differs from meter type relays in that it employs a chopper and an amplifying circuit to control to relay. It therefore offers considerably higher sensitivity, more rugged construction, and reliable non-locking as well as locking operation. It is fail-safe in that either chopper or tube failure will create the alarm condition. On either locking or non-locking operation the 701 is chatter-free. The unit may be mounted in the Model 7011 cabinet for convenient portability.

SECTION II - SPECIFICATIONS

Sensitivity: 0.2 to 10 millivolts

Input Resistance: 1 megohm

Differential between operate and release: 200 microvolts maximum

Permissible overload: greater than 100 times

Absolute zero stability: 100 microvolts

Repeatibility and Accuracy of trip point: 2% of full scale

Output: DPDT Relay 5 amps, 110 volts, non-inductive

Speed of Response: As shown in figure 1. Speed depends on the degree to which the trip point is exceeded. Reclosure times are approximately trip times.

Voltage Reference: 1 RM 12-R mercury battery. The battery life is in excess of 30,000 hours.

Tube Complement: 1-EF86, 1-12AX7, 1-2D21

Chopper: James C1281

Dimensions: 3" wide, 8" high, 13½" deep. Will mount five in a standard relay rack.

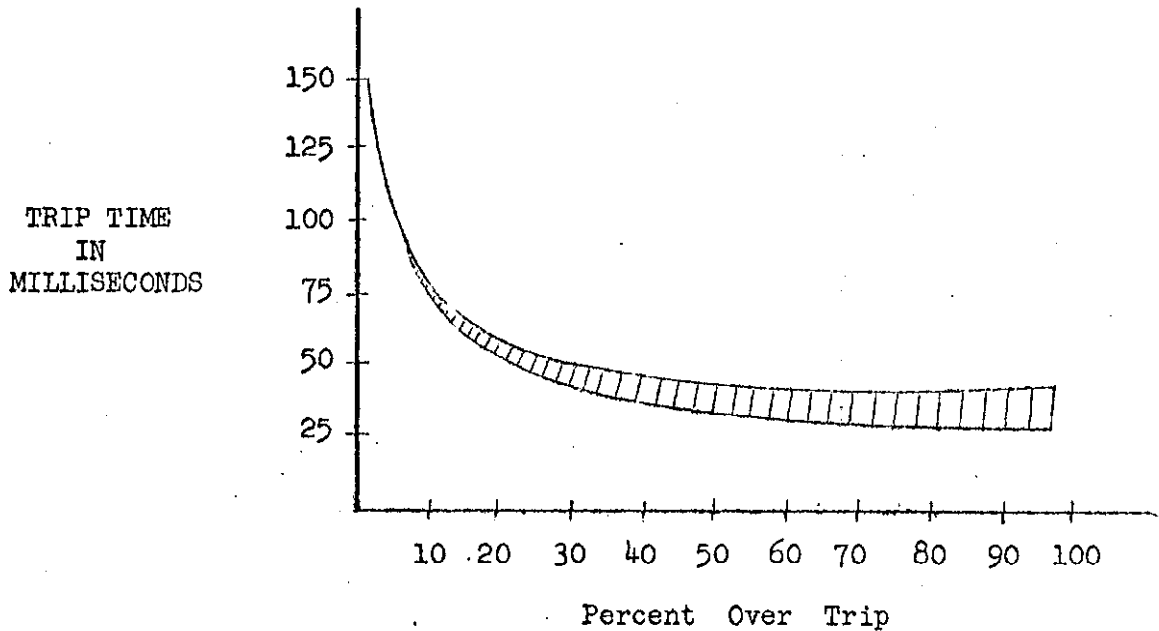

### SECTION III - DESCRIPTION

The Model 701 Electronic Relay consists of a three stage vacuum tube amplifier following a 60 cycle mechanical chopper. The output of the amplifier is synchronously demodulated and filtered to provide a D. C. signal at the grid of a thyatron. The thyatron operates a relay. Positive feedback from the thyatron grid to the input of the amplifier prevents relay chatter.

The voltage reference consists of a mercury battery across which is placed an accurate divider and a 1% linear potentiometer. The chopper compares the input voltage to the divider voltage. If the input voltage is less than the divider voltage the D. C. voltage to the thyatron grid keeps the thyatron on, if the input voltage exceeds the reference voltage the thyatron extinguishes. If circuit failure occurs, the signal to the demodulator, which keeps the thyatron on, is removed and the relay opens to indicate the alarm position.

The basic sensitivity of the instrument is 10 millivolts, however, provision is made for mounting internal dividers if reduced sensitivity is desired. Also, with an input impedance of one megohm currents down to  $10^{-8}$  amperes may be measured by means of shunt resistors.

## SECTION IV - OPERATIONS

INPUT CONNECTIONS - Connection to the input is made by means of a two pin connector. With the FLOATING - GROUNDED slide switch at the rear top of the chassis in the GROUNDED position, pin 2 is grounded to the chassis and pin 1 is the positive terminal. The input wires should be surrounded by a shield which is grounded to input connector shell. If it is desired to operate the input above ground, the slide switch should be placed in the floating position and connection made. The shield braid on the lead wires should be connected to the chassis, as before. For reliable operation, it may be necessary to shield the input circuitry.

OPERATING CONTROLS - The power is turned on at the front panel. Be sure that the instrument is wired for the proper line voltage. The 701 will operate satisfactorily on 50 or 60 cps. For method of changing line voltage consult schematic.

The trip point is set by means of the large dial on the front panel. The RELAY OPEN light will go on when the limit is exceeded. No other operating adjustments are necessary.

NON-LOCKING OPERATION - The instrument is normally supplied for non-locking operation and the relay will re-close when the signal drops more than  $1\frac{1}{2}\%$  below the set point.

LOCKING OPERATION AND CONVERSION TO LOCKING OPERATION - On the output plug at the rear of the instrument, pins 1 and 8 are jumpered. If this jumper is removed, the unit will perform as a locking relay. To reset, pins 1 and 8 must be momentarily shorted after the signal has fallen below the set limit. When units are supplied as locking relays, a reset button, connected across pins 1 and 8, is mounted on the front panel. In such units remote reset may be obtained by running wires from these pins. If a non-locking unit is converted to a locking type, reset may be provided by an external control across the reset pins or by installing a pushbutton in the hole provided on the panel.

REVERSE POLARITY AND LOW LIMIT OPERATION - If it is desired to have the unit actuate an alarm when the input voltage falls below the set point it is advisable to reverse the polarity of the leads to the chopper so that the relay will open when the signal falls below the set point. In this way the system is fail-safe for low limit rather than high limit operation.

If it is desired to operate on negative signals the battery is merely reversed in its holder. Correspondingly, if it is desired that the unit be fail-safe, the chopper lead-polarity should be so chosen so that the relay opens on exceeding the limit either from high or low as desired.

OUTPUT CONNECTIONS - The output is obtained as a DPDT set of contacts from a relay. The rating of the relay is 5 amperes NON-INDUCTIVE. If inductive loads or higher currents are to be switched, the output should be followed by a second relay of high enough current capacity.



## SECTION V - MAINTENANCE

The only maintenance required is the replacement of the mercury standard cell every 10,000 hours. If the highest reliability is required, it is recommended that the vacuum tubes also be replaced on that schedule.

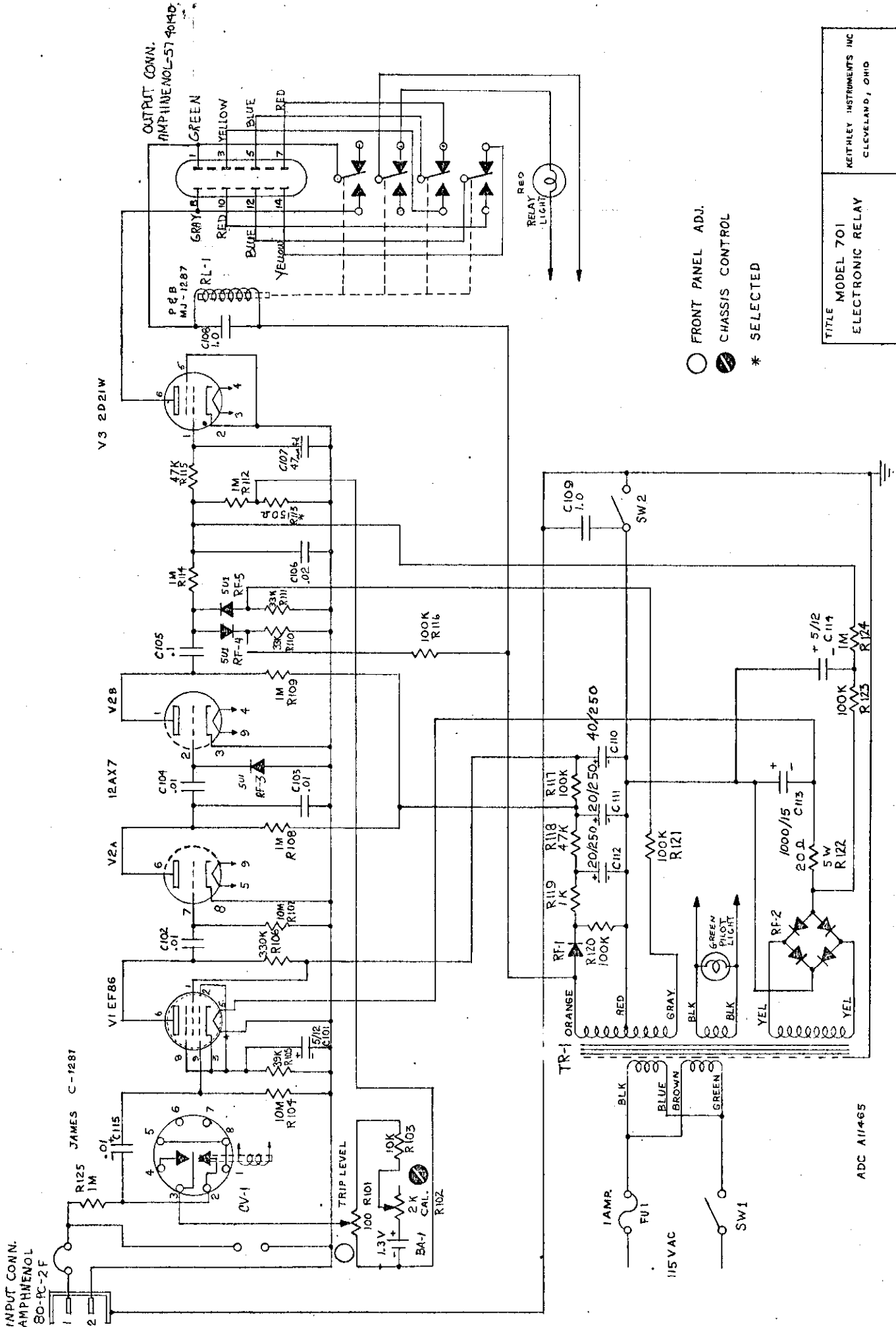

TITLE		MODEL 701	
ELECTRONIC RELAY		KEITHLEY INSTRUMENTS INC	
		CLEVELAND, OHIO	
DESIGNED	DATE	CHECKED	DATE
APPROVED	DATE	APPROVED	DATE

ADC A11465

13468 - C

# MODEL 701

## VOLTAGE AND RESISTANCE CHART

MEASUREMENTS MADE FROM TUBE PIN TO CHASSIS GROUND WITH CONTROLS SET AS FOLLOWS;

INPUT LEADS SHORTED TO GROUND.  
DIAL ADVANCED TO 10 MV POSITION.

SLIDE SWITCH IN GROUNDED POSITION.  
USE VTVM FOR MEASUREMENTS.

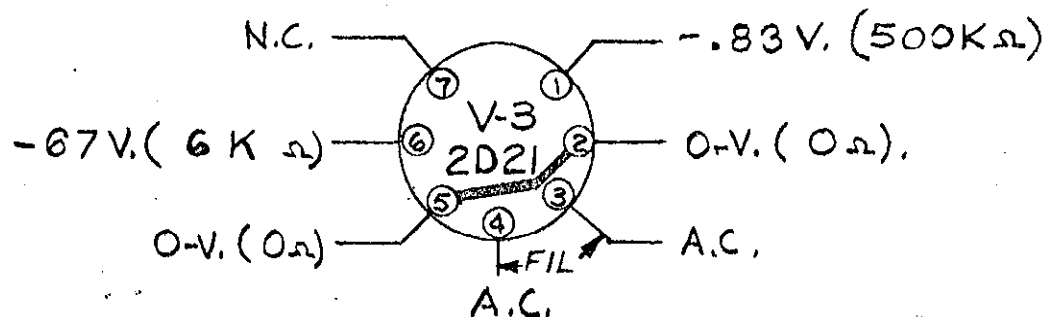
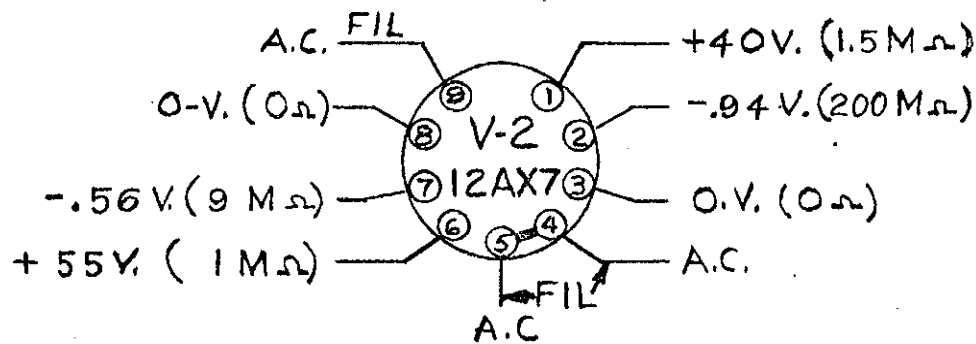
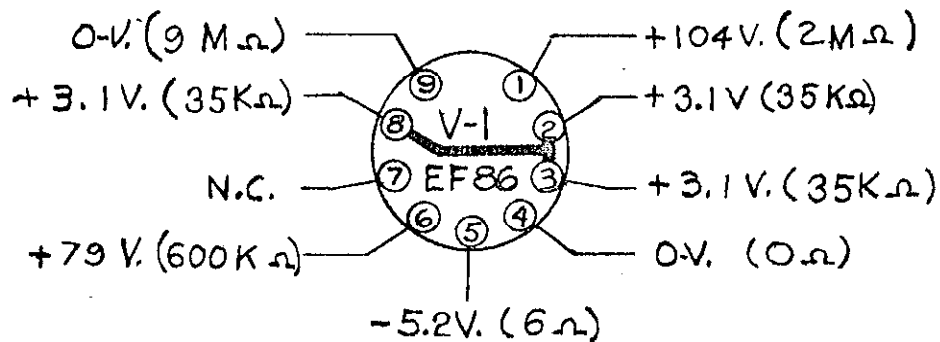

DR 12137-A

REPLACEABLE PARTS LIST - MODEL 701

Circuit Desig.	DESCRIPTION	PART NO.
BA-1	Battery - RM 12R, 1.3 V.	BA-7
C-101	Capacitor, Electrolytic, 5 mfd. 15 V.	C11-5
C-102	Capacitor, Disc Ceramic, .01 mfd. 600 V. 10%	C22-.01
C-103	Capacitor, Same as C-102	
C-104	Capacitor, Same as C-102	
C-105	Capacitor, Paper Metalized, 200 V. .1 mfd.	C18-.1
C-106	Capacitor, Disc Ceramic, .02 mfd. 600 V. 10%	C22-.02
C-107	Capacitor, Disc Ceramic, 47 mmf. 600 V. 10%	C22-47
C-108	Capacitor, Paper Metalized, 1. mfd. 200 V.	C18-1.0
C-109	Capacitor, Paper Metalized, 1. mfd. 400 V.	C19-1.0
C-110	Capacitor, Electrolytic, 40 - 250 W.V.D.	C27-40
C-111	Capacitor, Electrolytic, 20 - 250 W.V.D.	C27-20
C-112	Capacitor, Same as C-111	
C-113	Capacitor, Electrolytic, 1000 mfd. 15 V.	C11-1000
C-114	Capacitor, Electrolytic, Aluminum Case, 5 mfd. 15 V.	C11-5
C-115	Capacitor, Disc Ceramic, Same as C-102	
	Input Connector, Amphenol 80-PC-2F	CS-32
	Output Connector, Amphenol 57-40140	
	Input Plug, Amphenol 80-MC-2M	CS-33
	Output Plug, Amphenol 57-30140	
CV-1	Chopper, James Instruments, Vibrapower - C1281	
FU-1	Fuse, 1 ampere, 3 AG 250 V.	FU-8

## REPLACEABLE PARTS LIST - MODEL 701

Circuit Desig.	DESCRIPTION	PART NO.
R-101	Potentiometer, 100 ohms - General Radio, 901 VD	
R-102	Potentiometer, 2K, Wire Wound, 2 W.	RP-3
R-103	Resistor, Wire Wound, 10K	R18-16-10K
R-104	Resistor, Composition, 10 meg. $\frac{1}{2}$ W. 10%	R1-10M
R-105	Resistor, Composition, 39K. $\frac{1}{2}$ W. 10%	R1-39K
R-106	Resistor, Composition, 330K. $\frac{1}{2}$ W. 10%	R1-330K
R-107	Resistor, Composition, 10M. $\frac{1}{2}$ W. 10%	R1-10M
R-108	Resistor, Composition, 1M. $\frac{1}{2}$ W. 10%	R1-1M
R-109	Resistor, Same as R-108	
R-110	Resistor, Composition, 33K. $\frac{1}{2}$ W. 10%	R1-33K
R-111	Resistor, Same as R-110	
R-112	Resistor, Same as R-108	
R-113	Resistor, Composition, 150 ohms, $\frac{1}{2}$ W. 10%	R1-150
R-114	Resistor, Same as R-108	
R-115	Resistor, Composition, 47K $\frac{1}{2}$ W. 10%	R1-47K
R-116	Resistor, Composition, 100K. $\frac{1}{2}$ W. 10%	R1-100K
R-117	Resistor, Same as R-116	
R-118	Resistor, Same as R-115	
R-119	Resistor, Composition, 1K. $\frac{1}{2}$ W. 10%	R1-1K
R-120	Resistor, Composition, 100K. $\frac{1}{2}$ W. 10%	R1-100K
R-121	Resistor, Same as R-116	
R-122	Resistor, Ohmite, 20 ohms, 5 W. 10%	R4-20
R-123	Resistor, Same as R-116	
R-124	Resistor, Same as R-108	
R-125	Resistor, Same as R-108	

## REPLACEABLE PARTS LIST - MODEL 701

Circuit Desig.	DESCRIPTION	PART NO.
RF-1	Rectifier, Selenium, 130 V./65 ma	RF-18
RF-2	Rectifier Bridge, 130 V./65 ma	RF-7
RF-3	Diode, 5ul - International Rectifier Corp.	RF-15
RF-4	Same as RF-3	
RF-5	Same as RF-3	
RL-1	Relay, 4 P.D.T., P. & B. MJ 1287	
SW-1	Switch, Toggle, S.P.S.T. - on-off	SW-4
SW-2	Switch, D.P.D.T. - Floating or Ground	SW-45
TR-1	Transformer, ADC, A 11465	
V-1	Vacuum Tube, Type EF 86, Amperex	
V-2 A	Vacuum Tube, Type 12 AX7	EV-12AX7
V-2 B	Vacuum Tube, Same as V-2 A	
V-3	Gas Tube, Type 2 D2 1	EV-2D21